

# iDeal

aluminum

# Security Products

FENCE - GATES - HARDWARE







Ideal Aluminum has security products and expertise to assist you with your entire security project. Our clients have installed Ideal's products at government, military, religious, educational and commercial facilities. Ideal Aluminum's line of high security fencing and gates provide top-of-the-line perimeter defense to keep your facility secure and business in operation.

Ideal Aluminum's talon fence, with its arched features, helps deter and delay intruders. Ideal Aluminum's swing and slide gates are manufactured to the highest standards and can be adapted and connected to all security, call box and operator systems.

## HARDWARE



- MAMMOTH 180**
- Closing speed and final snap are individually adjustable
  - For gates Up to 150 kg
  - Maximum gate size 47" wide
  - ADA compliant; opening force of less than 3.5 lbs on 40" W gate with spring set to max closing force

- SAMSON 250**
- Closing pressure 250 N
  - For gates up to 80 kg
- SAMSON 400**
- Closing pressure 400 N
  - For gates up to 100 kg



**Samson 250N / 400N**  
Adjustable Horizontal Gate Closer

**Mammoth 180°**  
Gate Closer & Hinge In One

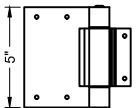

**iDeal 180° Hinge**  
Fits 4" Sq & Up Post Scale: NTS

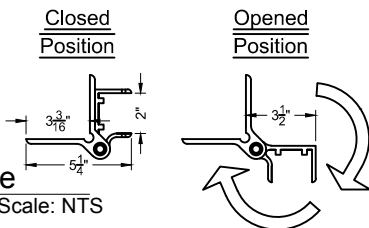

## TALON FENCE DETAILS

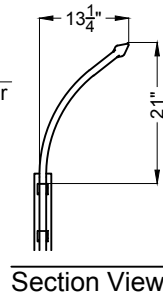
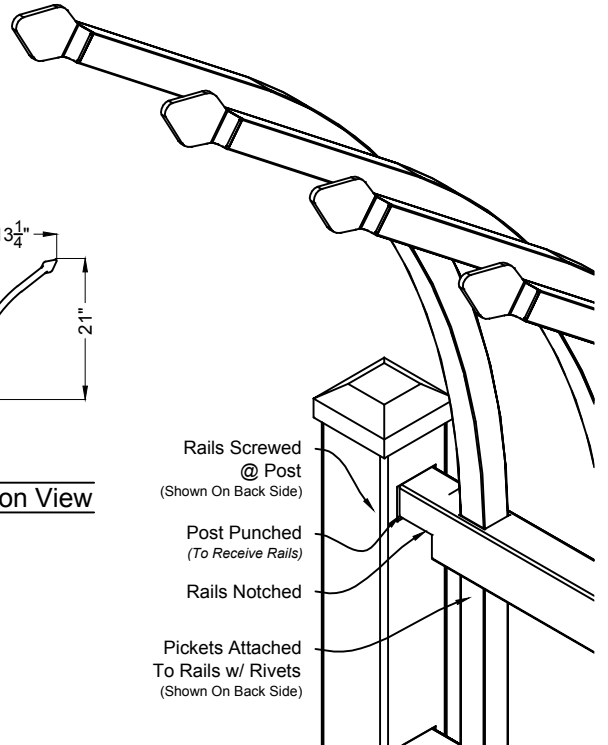

- Rails Screwed @ Post (Shown On Back Side)
- Post Punched (To Receive Rails)
- Rails Notched
- Pickets Attached To Rails w/ Rivets (Shown On Back Side)

**Detail A**

## STANDARD COLORS



Black White Bronze Hunter Green Custom Colors

\*actual colors may vary



www.ideal-ap.com  
Toll Free: 877.323.6496  
Fax: 877.226.4469

