

Detail - A

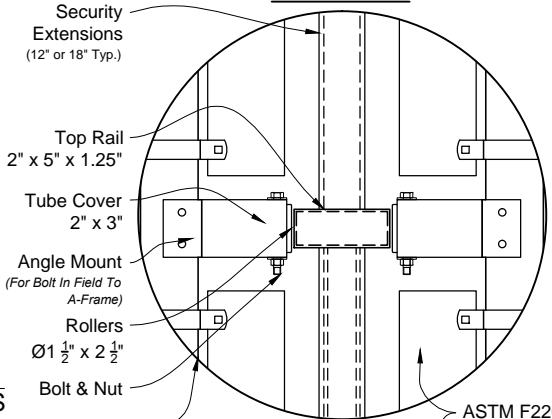

Detail - B

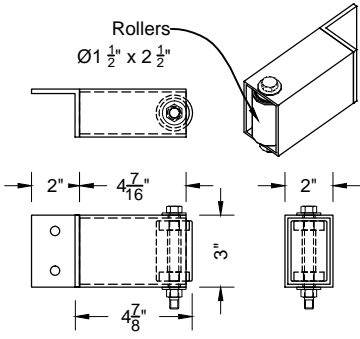
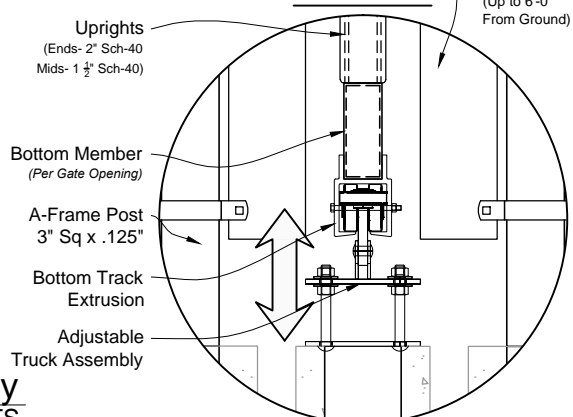

01 Guide Roller
Scale: NTS

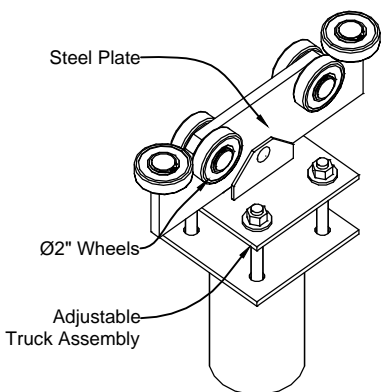

02 Truck Assembly
Scale: NTS

iDeals Bottom Track Cantilever Gate:

Ideal is the industry leader in bottom track cantilever gates. The Ideal bottom track cantilever gate offers distinct advantages over typical cantilever gates.

Our bottom track gate only requires 1/3 of the opening for the counter balance as opposed to 1/2 of the opening on a top track.

The weight of the gate falls naturally from the bottom of the gate to the truck assembly as opposed to hanging on the side of the gate like a top track. This results in less pressure on the track.

The truck assemblies allow for easy adjustment in the field.

Easy guide track minimizes sag and deflection

All of Ideals gates are fully welded out of heavy duty 6063-T5 structural aluminum and custom made to fit your exact opening.

Chain Link Bottom Track Cantilever Gate
Shown With Round Material



DRAWING NOTES:
Don't Scale From Drawings. Please See Our Gate Styles For Other Options. Arched And Scaloped Our Also Available.

Chain Link Bottom Track Standard Details

Approved By: iDeal Aluminum Quote #: _____
Drawn By: JMixon Drawn Date: 3-Nov-15

3200 Parker Drive Phone: 386.736.1700
St. Augustine, FL 32084 Fax: 386.822.4956